

TEST ZA STIPENDIJU / IUS SCHOLARSHIP TEST

Fakultet prirodnih i tehničkih nauka / *Faculty of Engineering and Natural Sciences (FENS)*

Arhitektura / *Architecture*¹

Elektrotehnika i elektronika / *Electrical and Electronics Engineering*¹

Mašinstvo / *Mechanical Engineering*¹

Računarske nauke i inženjering / *Computer Sciences and Engineering*^{1 2 3}

Softverski inženjering / *Software Engineering*

Umjetna inteligencija i inženjering podataka / *Artificial Intelligence and Data Engineering*

Pored redovnog IUS studija, postoji i program dvojne diplome s: / *In addition to regular IUS studies, there is also a double diploma program with:*

¹ Tehničkim univerzitetom u Istanbulu / *Istanbul Technical University*

² Istanbul univerzitetom / *Istanbul University*

³ Marmara univerzitetom / *Marmara University*

VAŽNE NAPOMENE / IMPORTANT NOTES

Ispit se sastoji od pitanja iz sedam obaveznih dijelova/polja. Svaki dio se sastoji od 10 pitanja. Svaki studijski program pojedinačno dodjeljuje poene određenim poljima tako da zbir poena u konačnici iznosi 100. Pogledajte tabelu ispod. / *The exam consists of questions from seven mandatory parts/fields. Each part consists of 10 questions. Each study program individually assigns points to each field, and the total points ultimately amount to 100. See the table below.*

FENS	AIDE/SE	CSE	EE	ME	ARCH
Matematika / <i>Mathematics</i>	30	30	40	30	20
Fizika / <i>Physics</i>	5	15	30	20	5
Biologija i hemija / <i>Biology and chemistry</i>	5	5	5	10	5
Logika / <i>Logic</i>	30	25	10	15	20
Arhitektura i umjetnost / <i>Architecture and arts</i>	10	5	5	5	30
Bosanski jezik / <i>Bosnian language</i>	10	10	5	10	10
Engleski jezik / <i>English language</i>	10	10	5	10	10
Ukupno / Total	100	100	100	100	100

PRVI DIO / PART 1: MATEMATIKA / MATHEMATICS

1. Krećući se ravnomjernom brzinom, za jedan sat Edin pređe 3,5 km pješačke staze. Koliko km pređe za pola sata? / *Moving at a constant speed, Edin covers 3.5 km of a walking trail in one hour. How many kilometers does he cover in half an hour?*
 - A. 1,25 / 1.25
 - B. 1,5 / 1.5
 - C. 1,75 / 1.75
 - D. 2
 - E. Nema tačnog odgovora / *No correct answer*
2. Koliko je x u jednačini: $\left(\frac{2}{3}\right)^x = \frac{16}{81}$? / *How much is x in the equation: $\left(\frac{2}{3}\right)^x = \frac{16}{81}$?*
 - A. 3
 - B. 4
 - C. 5
 - D. 6
 - E. Nema tačnog odgovora / *No correct answer*
3. U pravougaoniku, jedna stranica je 7 cm duža od druge, a njegov obim je 34 cm. Kolika je dužina dijagonale pravougaonika? / *In a rectangle, one side is 7 cm longer than the other, and its perimeter is 34 cm. What is the length of the rectangle's diagonal?*
 - A. 6
 - B. 12
 - C. 13
 - D. 35
 - E. Nema tačnog odgovora / *No correct answer*
4. Ako je $\frac{x-2y}{2x+y} = 3$, koliko je $\frac{x+3y}{3x-y} = ?$ / *If $\frac{x-2y}{2x+y} = 3$, how much is $\frac{x+3y}{3x-y} = ?$*
 - A. $\frac{1}{2}$
 - B. 4
 - C. $\frac{4}{3}$
 - D. $-\frac{1}{2}$
 - E. Nema tačnog odgovora / *No correct answer*
5. Ako je $3x - 7 = 2x + 5$, koliko je x? / *If $3x - 7 = 2x + 5$, how much is x?*
 - A. 9
 - B. 7
 - C. 15
 - D. 8
 - E. Nema tačnog odgovora / *No correct answer*

6. Pronađite korijene polinoma $2x^3 - 6x^2 - 2x + 6 = 0$. / *Find the root of the polynomial $2x^3 - 6x^2 - 2x + 6 = 0$.*
- A. $x = -1, 1, 3$
 - B. $x = 1, 2, 3$
 - C. $x = -3, 1, 3$
 - D. $x = -2, -1, 1$
 - E. Nema tačnog odgovora / *No correct answer*
7. Pronađite jednačinu kružnice koja prolazi kroz tačku (4, 1) i ima centar u tački (-2, 3). / *Find the equation of the circle that passes through the point (4, 1) and has its center at the point (-2, 3).*
- A. $(x + 2)^2 + (y - 3)^2 = 40$
 - B. $(x + 3)^2 + (y - 2)^2 = 40$
 - C. $(x + 2)^2 + (y - 3)^2 = 34$
 - D. $(x - 2)^2 + (y + 3)^2 = 34$
 - E. Nema tačnog odgovora / *No correct answer*
8. Otac je sinovima ostavio 160.000 KM sa željom da iznos podijele na jednake dijelove. Jedan sin se odrekao svog dijela, pa je ostalima nasljedstvo povećano za 8.000 KM. Koliko je sinova imao otac? / *The father left 160,000 KM to his sons with the wish to divide the amount equally between them. One son renounced his share, so the inheritance of the others increased by 8,000 KM. How many sons did the father have?*
- A. 4
 - B. 5
 - C. 6
 - D. 7
 - E. Nema tačnog odgovora / *No correct answer*
9. Riješite jednačinu $2^{3x} - 5 = 0$. / *Solve the equation $2^{3x} - 5 = 0$.*
- A. $\frac{3\log 5}{\log 2}$
 - B. $\frac{3\log 2}{\log 5}$
 - C. $\frac{\log 5}{2\log 3}$
 - D. $\frac{\log 5}{3\log 2}$
 - E. Nema tačnog odgovora / *No correct answer*

10. U pravouglom trouglu $\triangle ABC$, dužine kateta \overline{AC} and \overline{BC} su redom 30 cm i 40 cm. Ako je D središte hipotenuze, a E podnožje hipotenuzine visine, izračunati dužinu duži \overline{DE} . / In the right triangle $\triangle ABC$, the lengths of the legs \overline{AC} and \overline{BC} are 30 cm and 40 cm, respectively. If D is the midpoint of the hypotenuse, and E is the foot of the altitude to the hypotenuse, calculate the length of \overline{DE} .

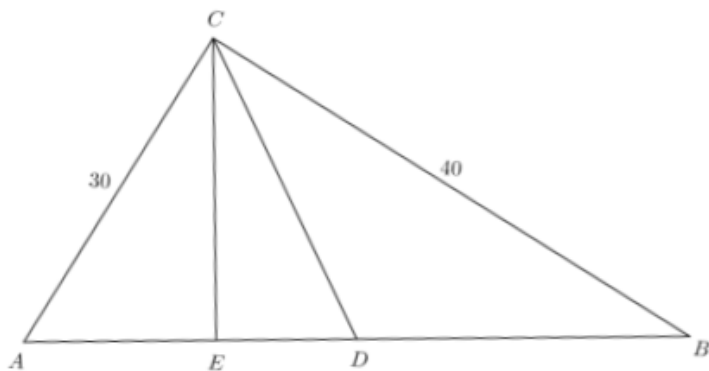

- A. 24
- B. 7
- C. 25
- D. 18
- E. Nema tačnog odgovora / No correct answer

DRUGI DIO / PART 2: FIZIKA / PHYSICS

1. Zakon koji definiše odnos električne struje, napona i otpora poznat je kao: / *The law that defines the relationship between the electric current, voltage, and resistance is known as:*
 - A. Treći Newtonov zakon / *Newton's Third law*
 - B. Teslin zakon / *Tesla's Law*
 - C. Fermijev zakon / *Fermi's Law*
 - D. Voltin zakon / *Volta's Law*
 - E. Ohmov zakon / *Ohm's Law*

2. Koji se naučnik smatra utemeljiteljem moderne astronomije? / *Which scientist is considered the founder of modern astronomy?*
 - A. Nicolaus Copernicus
 - B. Giordano Bruno
 - C. Isaac Newton
 - D. Galileo Galilei
 - E. Johannes Kepler

3. Grana fizike koja se bavi proučavanjem posljedica promjene pritiska, temperature i zapremine u makroskopskim fizičkim sistemima naziva se: / *The branch of physics that studies the effects of changes in pressure, temperature, and volume within macroscopic physical systems is called:*
 - A. kvantna mehanika / *quantum mechanics*
 - B. fizika čestica / *particle physics*
 - C. termodinamika / *thermodynamics*
 - D. elektromagnetika / *electromagnetics*
 - E. statistička fizika / *statistical physics*

4. Frekvencija predstavlja: / *Frequency is:*
 - A. rastojanje između dvije tačke koje se nalaze u istom stanju oscilovanja / *the distance between two points that are in the same oscillation state*
 - B. broj talasa koji prođu kroz određenu tačku u određenom vremenskom intervalu / *the number of waves that pass through a given point in a specific time interval*
 - C. energiju koja se kroz prazan prostor ili materijalnu sredinu širi u obliku elektromagnetnih talasa / *the energy that spreads through empty space or a material medium in the form of electromagnetic waves*
 - D. isto što i talasna dužina / *The same as wavelength*
 - E. prodorno elektromagnetno zračenje veoma kratke talasne dužine / *penetrating electromagnetic radiation of very short wavelength*

5. Koliko kelvina je jedanko nuli na Celzijusovoj skali (0°C)? / *How many Kelvins are equivalent to zero on the Celsius scale (0°C)?*
- A. 100
 - B. 173,15 / 173.15
 - C. 273,15 / 273.15
 - D. 373,15 / 373.15
 - E. 200
6. Predmet se kreće ravnomjernim ubrzanjem duž pravca. Šta se od navedenog odnosi na ukupnu silu koja djeluje na tijelo tokom kretanja? / *The object moves with uniform acceleration along a direction. Which of the following applies to the total force acting on the body during the motion?*
- A. Ukupna sila koja djeluje na tijelo ravnomjerno raste / *The total force acting on the body increases uniformly*
 - B. Ukupna sila koja djeluje na tijelo je jednaka nuli / *The total force acting on the body is equal to zero*
 - C. Ukupna sila koja djeluje na tijelo ravnomjerno opada / *The total force acting on the body decreases uniformly.*
 - D. Ukupna sila koja djeluje na tijelo je konstantna i nije jednaka nuli / *The total force acting on the body is constant and not equal to zero*
 - E. Nema tačnog odgovora / *No correct answer*
7. Data je jednačina harmonijskih vibracija $y(t) = 2\text{ cm sin}(628\text{ Hz } t)$. Kolika je frekvencija opisane vibracije? / *The harmonic vibration equation is given as $y(t) = 2\text{ cm sin}(628\text{ Hz } t)$. What is the frequency of the described vibration?*
- A. $f = 50\text{ Hz}$
 - B. $f = 75\text{ Hz}$
 - C. $f = 100\text{ Hz}$
 - D. $f = 200\text{ Hz}$
 - E. Nema tačnog odgovora / *No correct answer*
8. Dva broda jednake mase m plove jedan prema drugom u luci brzinom od 2 km/h i 5 km/h . U slučaju da ne uspiju da se mimoiđu, nakon sudara, plove zajedno kao jedno tijelo. Koliko brzo bi tada plovili? / *Two ships of equal mass m sail towards each other in a harbor at speeds of 2 km/h and 5 km/h . If they fail to avoid each other and collide, they will sail together as one body after the collision. How fast would they sail then?*
- A. 1 km/h
 - B. $1,5\text{ km/h}$ / 1.5 km/h
 - C. $2,5\text{ km/h}$ / 2.5 km/h
 - D. 3 km/h
 - E. Nema tačnog odgovora / *No correct answer*

9. Prema prethodnom pitanju: kakva bi bila orijentacija kretanja nakon neelastičnog sudara? / *According to the previous question: what would be the orientation of the motion after an inelastic collision?*
- orijentacija kretanja bržeg broda (brodovi nastavljaju da se kreću u pravcu bržeg broda) / *the movement orientation of the faster ship (the ships continue to move in the direction of the faster ship)*
 - orijentacija kretanja sporijeg broda (brodovi nastavljaju da se kreću u pravcu sporijeg broda) / *the orientation of the movement of the slower ship (the ships continue to move in the orientation of the slower ship)*
 - prosječna orijentacija kretanja (brodovi nastavljaju da se kreću sa prosječnom orijentacijom oba broja) / *the average movement orientation (the ships continue to move with the average orientation of both numbers)*
 - brodovi se ne bi kretali / *the ships would not move*
 - smjer kretanja se ne može odrediti / *the direction of motion cannot be determined*

10. Monohromatsko svjetlo osvjetljava metalnu površinu. Promjenom frekvencija svjetlosti dešava se da se sa površine metala emituju elektroni na tačno određenim frekvencijama. Kinetička energija generisanih fotoelektrona ovisi o frekvenciji upadne svjetlosti. Ova zavisnost je prikazana grafički. Odgovarajuća jednačina je: / *A monochromatic light illuminates a metal surface. By changing the frequencies of light, electrons are emitted from the surface of the metal at precisely determined frequencies. The kinetic energy of the generated photoelectrons depends on the frequency of the incident light. This dependence is demonstrated graphically. The corresponding equation is:*

$$A f = B + E_k \text{ za } f > f_0$$

$$E_k = 0 \text{ za } f \leq f_0$$

gdje su A i B pozitivne konstante. / *where A and B are positive constants.*

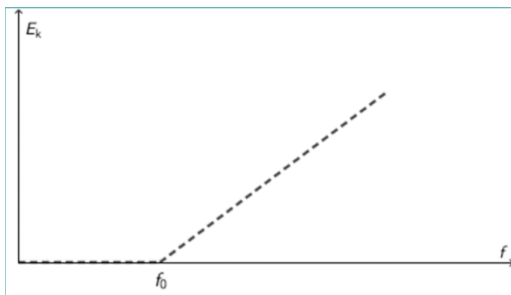

Izrazite f_0 kroz konstante A and B . / *Indicate f_0 through the constants A and B .*

- $f_0 = A/B$
- $f_0 = B/A$
- $f_0 = A \times B$
- $f_0 = A + B$
- Nema tačnog odgovora / *No correct answer*

TREĆI DIO / PART 3: BIOLOGIJA I HEMIJA / BIOLOGY AND CHEMISTRY

1. Za razliku od anorganskih spojeva, organski spojevi uvijek sadrže element: / *Unlike inorganic compounds, organic compounds always contain the element:*
 - A. kisik / *oxygen*
 - B. olovo / *lead*
 - C. ugljik / *carbon*
 - D. dušik / *nitrogen*
 - E. željezo / *iron*
2. Aldehidi i ketoni su spojevi koji sadrže: / *Aldehydes and ketones are compounds that contain:*
 - A. amino grupu / *an amino group*
 - B. karbonilnu grupu / *a carbonyl group*
 - C. hidroksilnu grupu / *a hydroxyl group*
 - D. karboksilnu grupu / *a carboxyl group*
 - E. anionsku grupu / *an anionic group*
3. Po definiciji, lipidi su: / *By definition, lipides are:*
 - A. esteri viših masnih kiselina i aldehida / *esters of higher fatty acids and aldehydes*
 - B. esteri viših masnih kiselina i amina / *esters of higher fatty acids and amines*
 - C. esteri viših masnih kiselina i etera / *esters of higher fatty acids and ethers*
 - D. esteri viših masnih kiselina i alkohola / *esters of higher fatty acids and alcohols*
 - E. eteri viših masnih kiselina i ketona / *ethers of higher fatty acids and ketones*
4. Osnovna gradivna jedinica svih živih bića je: / *The basic building unit of all living beings is:*
 - A. ćelija / *the cell*
 - B. tkivo / *tissue*
 - C. organ / *the organ*
 - D. voda / *water*
 - E. šećer / *sugar*
5. Prvi Mendelov zakon se naziva zakon uniformnosti F1 generacije. Koja od datih tvrdnji odgovara datom zakonu? / *The first Mendelian law is called the law of uniformity of the F1 generation. Which of the following statements corresponds to this law?*
 - A. Sve jedinke u F1 generaciji su fenotipski i genotipski različite / *All individuals in the F1 generation are phenotypically and genotypically different.*
 - B. Sve jedinke u F1 generaciji su fenotipski i genotipski iste / *All individuals in the F1 generation are phenotypically and genotypically identical.*
 - C. Sve jedinke u F1 generaciji su genotipski iste, a fenotipski različite / *All individuals in the F1 generation are genotypically identical but phenotypically different.*
 - D. Sve jedinke u F1 generaciji su klonovi svojih genotipa / *All individuals in the F1 generation are clones of their genotypes.*
 - E. Sve jedinke u F1 generaciji su fenotipski iste, a genotipski različite / *All individuals in the F1 generation are phenotypically identical but genotypically different.*

6. Nauka koja proučava gene i hromosome zove se: / *The science that studies genes and chromosomes is called:*
- A. citologija / *cytology*
 - B. medicina / *medicine*
 - C. histologija / *histology*
 - D. anatomija / *anatomy*
 - E. genetika / *genetics*
7. Histoni su po definiciji: / *Histones are defined as:*
- A. lanac polisaharida koji služi u odmotavanju DNK u jezgri / *a chain of polysaccharides used in DNA unwinding in the nucleus*
 - B. kratki lanac masnih kiselina koji potpomaže translaciju / *a short chain of fatty acids that aids the process of translation*
 - C. mali proteini koji služe u omotavanju molekule DNK u nukleosomu / *small proteins that wrap DNA molecules into nucleosomes*
 - D. mali proteini koji ubrzavaju DNA transkripciju / *small proteins that speed up DNA transcription*
 - E. lanac masti koji štiti DNK od odmotavanja / *a chain of fats that protects DNA from unwinding*
8. Transport jona/ionu u ćeliju (i iz ćelije) se odvija: / *Ion transport in and out of the cell occurs via:*
- A. aktivnim transportom kroz jonske kanale / *active transport through ion channels*
 - B. pasivnim transportom pomoću transportnih proteina / *passive transport by transport proteins*
 - C. osmozom / *osmosis*
 - D. difuzijom / *diffusion*
 - E. potpomognutim transportom pomoću lipida / *facilitated transport with lipids*
9. Molekula DNK ima sposobnost: / *A DNA molecule has the ability of:*
- A. samoreparacije / *self-repair*
 - B. autolize / *autolysis*
 - C. pinocitoze / *pinocytosis*
 - D. autoreprodukcije / *self-replication*
 - E. fagocitoze / *phagocytosis*
10. Kod DNK u sastav heterocikličnih baza ulaze: / *The heterocyclic bases in DNA consist of:*
- A. adenin, guanin, citozin i timin / *adenine, guanine, cytosine, and thymine*
 - B. adenin, guanin i citozin / *adenine, guanine, and cytosine*
 - C. adenin i citozin / *adenine and cytosine*
 - D. citozin i timin / *cytosine and thymine*
 - E. timjan i guanozin / *thymine and guanosine*

ČETVRTI DIO / PART 4: LOGIKA 2 / LOGIC 2

1. Koji je oblik izrezan iz pravougaonika? Oblik se može okretati. / Which shape has been cut out from the rectangle? The shape can be rotated

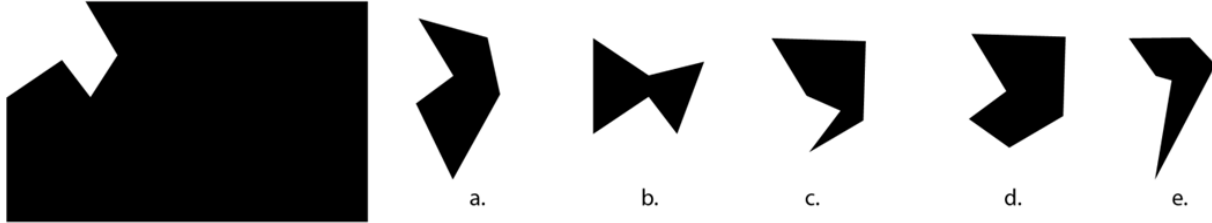

2. Prepoznajte uzorak koji se ponavlja: / Recognize the repeating pattern:

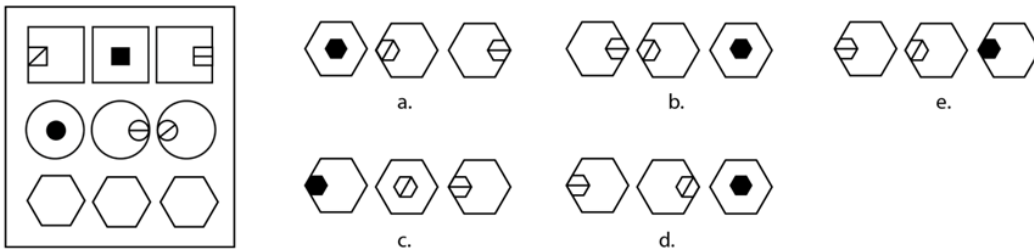

3. Koji dio nedostaje na slici? / Which part is missing in the picture?

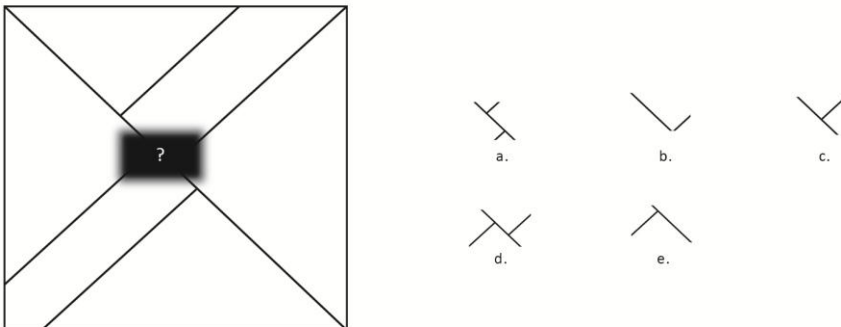

4. Koji od sljedećih oblika ne pripada skupini? / Which of the following shapes does not belong to the group?

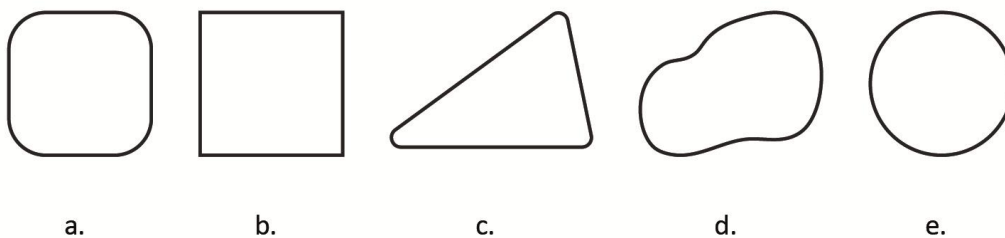

5. Nastavi slijed: / *Continue the sequence:*

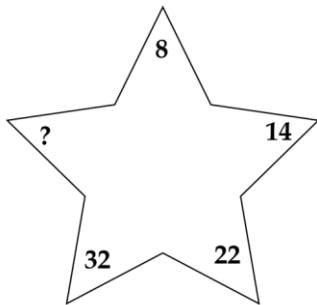

41 44 38 46 40
a. b. c. d. e.

6. 10 radnika proizvede 10 čaša za 5 minuta. Za koliko će minuta 50 radnika proizvesti 50 čaša? / *10 workers produce 10 glasses in 5 minutes. How many minutes will it take for 50 workers to produce 50 glasses?*
- A. 5
B. 10
C. 15
D. 20
E. 50
7. Ako je GAKO GOKA, 7183 je: / *If GAKO is GOKA, then 7183 is:*
- A. 7318
B. 7381
C. 7813
D. 8137
E. 7138
8. U nizu 10O12, 14P16, 18R20, sljedeća skupina je: / *In the sequence 10O12, 14P16, 18R20, the next group is:*
- A. 20S20
B. 22S22
C. 22S24
D. 22Š22
E. 22Š24
9. Na jednom kraju vage nalazi se lubenica, a na drugom kraju pola takve lubenice i uteg težak 4 kg. Vaga je u ravnoteži. Koliko je teška cijela lubenica? / *At one end of a scale, there is a watermelon, and at the other end, half of such a watermelon and a 4 kg weight. The scale is balanced. How much does the whole watermelon weigh?*
- A. 2 kg
B. 6 kg
C. 9 kg
D. 8 kg
E. 4 kg

10. Nana ima 65 a unuka 5 godina. Za koliko će godina nana biti pet puta starija od unuke? / *Grandma is 65 years old, and her granddaughter is 5 years old. In how many years will Grandma be five times older than her granddaughter?*
- A. 5
 - B. 10
 - C. 15
 - D. 20
 - E. 25

PETI DIO / PART 5: UMJETNOST I ARHITEKTURA / ARTS AND ARCHITECTURE

1. Označite crtež presjeka kroz prikazano geometrijsko tijelo: / *Mark the cross-section drawing through the displayed geometric body:*

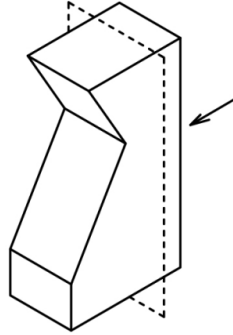

A



B



C

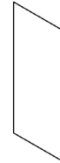

D



E

2. Označite nacrt prikazane geometrijske figure iz označenog pravca: / *Mark the drawing of the displayed geometric figure from the indicated direction:*

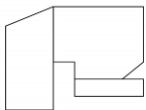
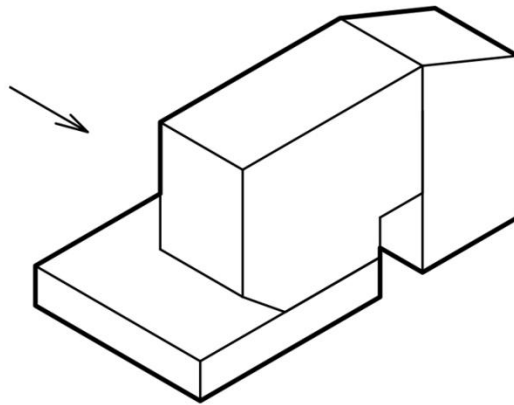

A

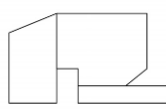

B

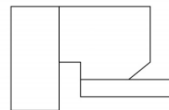

C

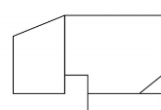

D

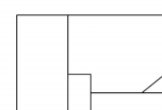

E

3. Koji od prikazanih oblika u aksonometriji odgovara priloženoj mreži? / Which of the displayed axonometric shapes corresponds to the provided grid?

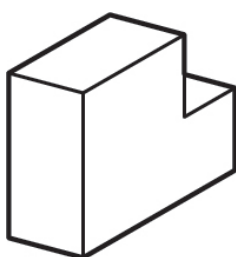
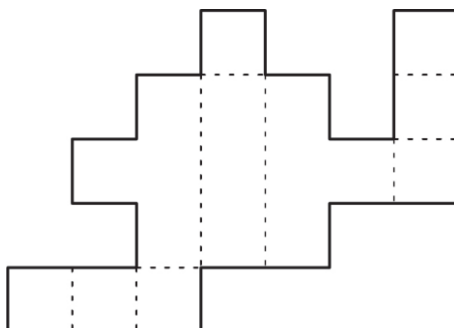

A

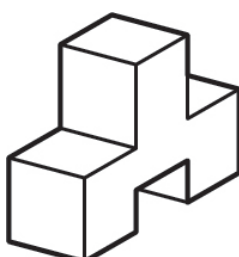

B

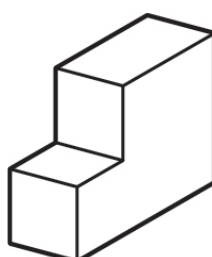

C

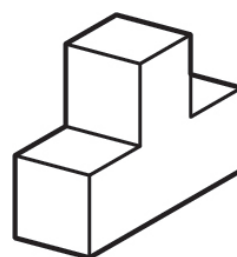

D

Nijedan od navedenih / None of the displayed

E

4. Koji od prikazanih crteža je tlocrt objekta u aksonometriji? / Which of the axonometric drawings corresponds to the displayed floor plan?

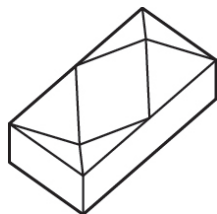
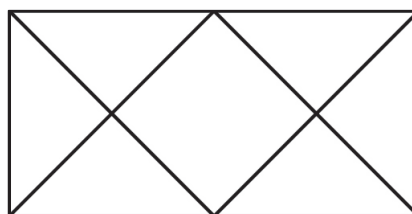

A

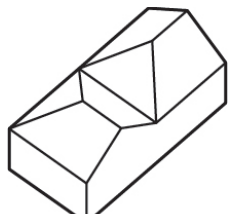

B

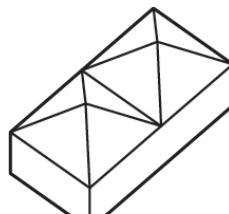

C

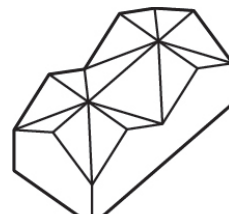

D

Nijedan od navedenih / None of the displayed

E

5. Koji od prikazanih crteža je tlocrt objekata u aksonometriji? / Which of the displayed drawings is the floor plan of the objects in axonometry?

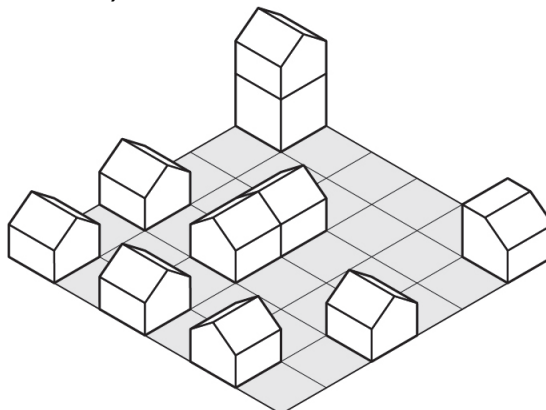

				Nijedan od navedenih / None of the displayed
A	B	C	D	E

6. Površine tri različite stranice kutije su 6, 8, 12. Kolika je njena zapremina? / The areas of the three different faces of a box are 6, 8, and 12. What is its volume?

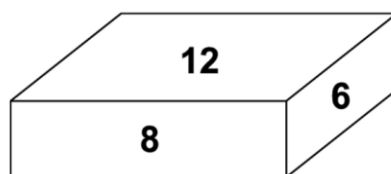



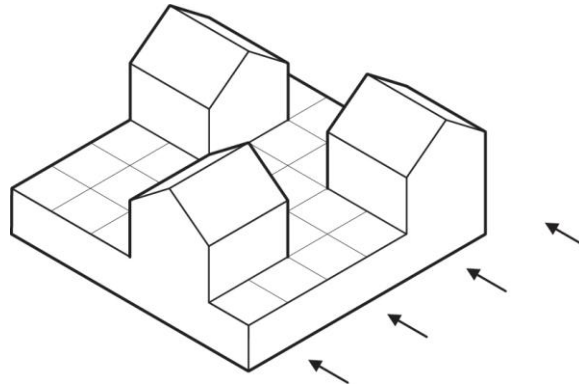

- A. 24 B. 26 C. 48 D. 52 E. 56

7. Alhambra je: / Alhambra is:
- A. latino-američki ples / a Latino-American dance
 - B. grčki filozof / a Greek philosopher
 - C. džamija u Maroku / a mosque in Morocco
 - D. maurska palača u Španiji / a Moorish palace in Spain
 - E. muzej u Parizu / a museum in Paris

8. Kojem pogledu iz označenog pravca odgovaraju nacrti priloženog objekta u aksonometriji? / To which view from the indicated direction do the drawings of the presented object in axonometry correspond?



		Nijedan od navedenih / None of the displayed		
A	B	C	D	E

9. Zgrada na slici je: / The building in the picture is:



- A. Krivi toranj u Pisi / *The leaning tower of Pisa*
- B. Opera u Sydneju / *The Sydney Opera*
- C. Sveti Petar u Rimu / *St. Peter's Basilica in Rome*
- D. Notre Dame u Parizu / *The Notre Dame in Paris*
- E. Taj Mahal u Indiji / *The Taj Mahal in India*

10. Zgrada na slici je: / The building in the picture is:



- A. Pompidou centar u Parizu / *The Pompidou Center in Paris*
- B. Guggenheim muzej u Bilbau / *The Guggenheim museum in Bilbao*
- C. Opera u Sydneju / *The Sydney Opera House*
- D. Kapela Ronschamp / *The Ronschamp chapel*
- E. Tate galerija u Londonu / *The Tate gallery in London*

ŠESTI DIO / PART 6: BOSANSKI JEZIK / BOSNIAN LANGUAGE

1. Koja od navedenih je pravilno napisana skraćenica?
 - A. i. t. d.
 - B. i t. d.
 - C. i t.d.
 - D. itd
 - E. itd.

2. Zaokruži slovo ispred pravilno napisane rečenice.
 - A. Mi bismo željeli posjetiti Zemaljski muzej u Sarajevu.
 - B. Mi bi smo želili posjetiti Zemaljski Muzej u Sarajevu
 - C. Mi bismo željeli posjetit zemaljski Muzej u Sarajevu.
 - D. Mi bi željeli posjetiti Zemaljski muzej u Sarajevu.
 - E. Mi bi željeli posjetit zemaljski Muzej u Sarajevu.

3. Žensko ime Iris u vokativu će glasiti:
 - A. Iriša
 - B. Iriši
 - C. Irišo
 - D. Iriš
 - E. Iriše

4. Koji od sljedećih književnih likova se pojavljuje u Selimovićem romanu Tvrđava?
 - A. Ahmet Šabo
 - B. Latifaga Karađoz
 - C. Ćamil efendija
 - D. Salko Ćorkan
 - E. Ahmed Nurudin

5. Kojim pismom je pisana povelja Kulina bana?
 - A. Glagoljicom
 - B. Arapskim
 - C. Bosančicom
 - D. Latinicom
 - E. Ćirilicom

TEKST 1

Odlomak (Ruso, 1762/1989).

_____ Nije slobodna riječ koja ne znači ništa, nego je ta riječ nužda. Pretpostaviti kakvu radnju, kakvu posljedicu koja ne ističe iz nekoga aktivnog principa, znači uistinu pretpostaviti posljedice bez uzroka, a to je upasti u „*circulus vitiosus*“. Ili nema uopšte prvoga impulsa, ili nijedan prvi impuls nema nijednoga ranijeg uzroka, i onda nema prave volje bez slobode. _____ To je moj treći član vjere. Iz ta tri prva člana lako ćeš moći izvesti sve ostale, a da ih ne moram dalje nabrajati.

Ako je čovjek aktivan i slobodan, on radi iz vlastite pobude; sve su njegove slobodne radnje nezavisne od sistema što ga je providenje uredilo, te mu ne mogu biti pripisane. _____. Ali ga **ono** ne sprečava u činjenju zla, bilo što je zlo, koje čini jedno tako slabo biće, u njegovim očima sasvim beznačajno, bilo što ga ono ne može u tom spriječiti a da pritom ne skući njegovu slobodu i da ne prouzrokuje još veće zlo ponižavanjem njegove prirode. Ono ga je stvorilo slobodnim da se po slobodnom izboru odluči ne za zlo nego za dobro. Ono ga je također stavilo u mogućnost da vrši taj izbor uz pravilnu upotrebu sposobnosti kojima ga je obdarilo. Ali je ono tako ograničilo njegove sile da zloupotreba slobode, koju mu ono dopušta, ne može narušiti opšti red. Zlo što ga čovjek čini, pada na njega, a da usljed toga ne napusti ni najmanja promjena u poretku svijeta i da s tim ne spriječi da se ljudski rod i dalje održi, ako i ne bi htio. Gundati zbog toga što Bog ne sprečava činjenje zla, znači gundati zbog toga što je on ljudskom rodu dao tako visoke sposobnosti, što je u ljudske radnje unio moralnost koja ih oplemenjuje i što je ljudima dao pravo na vrlinu. _____. Upravo stoga da bismo zaslužili i postigli to zadovoljstvo, stavljeni smo na ovu Zemlju, obdareni smo slobodom, dovode nas u iskušenje naše strasti i obuzdava nas naša savjest. Šta je mogla i sama božanska svemoć da učini više u našu korist?

6. Pravilno poredajte rečenice koje nedostaju u odlomku.
- i. *Najveće je uživanje u zadovoljstvu samim sobom.*
 - ii. *Čovjek je, prema tome, slobodan u svojim radnjama i, kao takvo slobodno biće, oživotvoren nematerijalnom supstancijom.*
 - iii. *Ono ne traži zlo što ga čovjek čini zloupotrebljavajući slobodu koju mu ono daje.*
 - iv. *Izvor svake radnje je u volji slobodnoga bića; ne možemo dokazati dublji uzrok.*
- A. iv, ii, iii, i
B. ii, i, iv, ii
C. iii, i, ii, iv
D. i, iv, ii, iii
E. iv, i, ii, iii
7. U prvom paragrafu odlomka u prethodnom pitanju, fraza „*circulus vitiosus*“ znači:
- A. naivna zavrzlama
 - B. nepotpuno zaključivanje
 - C. konstantno odlučivanje
 - D. proizvoljno zaključivanje
 - E. kružno dokazivanje

8. Riječ **ono** u drugom paragrafu odlomka odnosi se na:
- A. činjenje zla
 - B. proviđenje
 - C. zlo
 - D. ponižavanje čovjekove prirode
 - E. slobodno odlučivanje

TEKST 2

Odlomak (Vegara, 2018).

Biti žena u 21. stoljeću znači konstantnu borbu za izlaz iz nametnutog podređenog položaja u apsolutno "muškom svijetu", a biti žena u poslijeratnoj bh. kinematografiji, gledajući s jedne strane likove i karaktere koje portretiraju u filmovima, i s one druge, iza kamere, označava ženske društvene borbe koji, osim tradicionalnih, kulturoloških i historijskih ožiljaka, i dalje odišu neprevaziđenom ljepotom.

"Lik žene u postratnom bh. filmu doživljava potpuni preobražaj. Tek se u ovom periodu počinju snimati filmovi sa jakim i slojevitim glavnim ženskim likovima koji prevazilaze uobičajne obrasce žene kao majke ili žene kao seksualnog objekta. U savremenom bh. filmu ženski likovi su mnogo raznovrsniji te ih možemo vidjeti kao žene žrtve, žene buntovnice, žene autsajderke, uglavnom jake žene koje su trodimenzionalne", govori scenaristica Elma Tataragić, dodajući da je zanimljiv odnos scenarista i scenaristica, te režisera i režiserki prema ženskim likovima, ali i prema muškima. "Mislim da se savremeni bh. film ozbiljnije i temeljitije bavi pozicijom žene u našem društvu, te je samim tim i odnos prema ženskim likovima dublji."

9. U kontekstu ovog odlomka, koji je od navedenih zaključaka tačan?
- A. Tataragić misli da savremena bh. kinematografija projektira stereotipne ženske likove.
 - B. Tataragić misli da savremena bh. kinematografija projektira provokativne ženske likove.
 - C. Tataragić misli da savremena bh. kinematografija viktimizira ženske likove.
 - D. Tataragić misli da savremena bh. kinematografija problematizira ženske likove.
 - E. Tataragić misli da savremena bh. kinematografija projektira kompleksnije ženske likove.
10. Odlomak iz prethodnog pitanja je pretežno fokusiran na temu:
- A. kinematografija danas
 - B. kinematografija i društvo
 - C. žena u 21. stoljeću
 - D. žene kao inspiracija i izvor filmskih priča
 - E. stanje kinematografije

SEDMI DIO / PART 7: ENGLISH

GRAMMAR AND VOCABULARY

Choose the correct answer – A, B, C, D or E.

1. not talking so loudly? We are trying to sleep.
 - A. If you could
 - B. Could you
 - C. Would you mind
 - D. Would you
 - E. Can you

2. The teacher asked Lejla
 - A. if she feels ill
 - B. if she felt ill
 - C. does she feel ill
 - D. did she feel ill
 - E. do you feel ill

3. Ahmed doesn't have internet connection at home, puts him at a disadvantage when it comes to schoolwork.
 - A. where
 - B. that
 - C. who
 - D. which
 - E. why

4. If only Alice for the exam, she would have passed it.
 - A. studied
 - B. have studied
 - C. would have studied
 - D. would study
 - E. had studied

5. Bruce is going to the doctor next week to have
 - A. his lungs checked
 - B. check his lungs
 - C. his lungs check
 - D. checked his lungs
 - E. been checked his lungs

READING

TEXT ONE

Read the text. For questions 6–10, choose the correct answer – A, B, C, D or E.

SAVING PLANET EARTH

Is it too late to save the planet? Fiona Gibbons thinks we can do it – if we stop to think about it.

Most people recognise that the Earth is facing some major problems. But whether or not the damage is caused by us, it is up to us to find solutions because those of us who live in industrial societies are certainly not *helping* the situation.

Many scientists agree that global warming is caused by us releasing carbon emissions into the atmosphere. We need to look at where this carbon comes from, and the answer is fossil fuels. We have been taking oil, coal and gas out of the earth for many years now, and it's time to ask a simple question: How long can we keep taking it before it runs out? Even if there are enough fossil fuels for the next hundred years, we will have to find new sources of energy after that. We can't ignore the problem and leave it for the next generation to solve instead of developing the alternatives.

We have the technology to use energy from the sun to heat our houses. If we all put solar panels on the roofs of our houses, we will not need to use heating oil. We will need much less electricity too. We have to remember that electricity, as clean and convenient as it is, is mostly produced by burning fossil fuels. So, although we might not see the pollution this causes, it is still harming the atmosphere in a major way. Solar panels make use of energy which costs nothing – energy which is given off by the sun every day. And the latest technology captures *daylight*, not sunlight, so that even on a cloudy day, or in countries with very little sunshine, we still get free energy.

Wind energy too can be harnessed to make electricity. In many countries, there are already companies selling wind turbines to householders. They're expensive, but they also generate a lot of electricity without causing smog. In an average case, a wind turbine on your roof will save enough money on your electricity bill to pay for itself in ten years. If you live in a windy spot, or if you buy one of the bigger turbines, you will generate more electricity than you need. You can then sell this energy back to the electricity company – you will not only save money on your bills and help protect the environment, but you will make a profit too!

What if you can't afford a solar panel? What if you don't own your own house? Individual efforts are great, but governments need to react to the situation as well. The wind turbines that have been mentioned above can be gathered together in one place. This is called a wind farm. Together, all these turbines can produce enough electricity for a small town. The energy produced by waves can also be used to make electricity in a similar way. But these 'green' power stations can only be built if governments decide to spend money on them.

Unfortunately, one of the main reasons they don't is that members of the public complain that they are ugly. So this brings the problem back to the individual. What would you rather see out of your window: a wind farm generating free electricity under a clear blue sky, or a typical power station with thick, black smoke pouring into the atmosphere?

The majority of us take electricity for granted. Most of our homes are powered by it and we rarely give a thought to where it comes from. It's difficult to see that, every time we leave a light on, a power station somewhere is burning fossil fuels and polluting the air that we breathe. We all need to think seriously about this. And if enough people get together, governments will be forced to change their policies. The future of the planet depends on it.

6. The writer says that the energy we get from fossil fuels:
 - A. is better than the alternatives.
 - B. is a new source of energy.
 - C. will need to be replaced.
 - D. helps solve a problem.
 - E. is going to remain equally important as it is now.

7. What does the writer say about modern solar panels?
 - A. They work even at night.
 - B. They work when the sun is not shining.
 - C. They are less harmful than older panels.
 - D. They still cause some pollution.
 - E. They can't produce enough energy to meet our needs.

8. What does the writer say about putting a wind turbine on your roof?
 - A. You can sell it when you have finished with it.
 - B. It won't work if it's very windy where you live.
 - C. A small one won't save you any money.
 - D. It's economical in the long term.
 - E. They can still cause smog.

9. Wind farms are unpopular because:
 - A. people don't like to look at them.
 - B. they only supply urban areas.
 - C. they still pollute the atmosphere.
 - D. governments spend too much money on them.
 - E. people can't see a clear blue sky because wind turbines are too big.

10. The writer thinks that electricity is something that:
 - A. we should learn to live without.
 - B. governments will never decide to support financially.
 - C. most people think about a lot.
 - D. will not exist in the future.
 - E. we should produce in a cleaner way.